



**EXPLOSION PROOF CHECK
VALVE TYPE SEW6 SERIE 3X
ATEX DIRECTIVE & CENELEC STANDARD**



CARACTERISTICS

Hydraulic :

Cetop 3.
Maximum service pressure : 250 Bar.
Nominal flow max. : 11 l/mn.
4 hydraulic symbols : 4/2 et 3/2.
No leakage inside.
With or without pushbutton.

Electric :

Protection index : IP 66.
ATEX Directive & IECEx
Non-Mining : II 2 GD EExd or EExde, Group I or IIB+H2.
Temperature range : T6, T5, T4.
Mining : EEx"d" ou EEx"de", I M2.
Connections on terminal box or taped flange.



M-3 SEW6 C 3X-7 / 420 / Ex700 24-DC-T5 H1d

DESCRIPTION OF FUNCTION

Operated check valve type SEW6, are solenoid operated directional ball valves. They control start stop and direction of oil flow.

The valves basically consist of the housing (1), one solenoid (2) seat-valve unit (3), hardened steel ball (4). The force of the solenoid (2) acts via the lever (6) on the check (7) and on the control push (8) .

The filter in alimentation protect the check valve from too much clog.

The spring (9) lock the check on the valve seat in neutral position from the solenoid (2) in work position.

VALVE 3/2 :

Symbol U valve with 1 check :

- neutral position : flow from P to A, T locked without leakage.
- work position : flow from A to T, P locked without leakage.

Symbol C valve with 2 checks

- neutral position: flow from A to T, P locked without leakage
- work position: flow from P to A, T locked without leakage.

VALVE 4/2 :

Symbol D :

3/2 valve symbol U with 1 check and with 1 plate.

Symbol Y :

3/2 valve symbol C with 2 checks and with 1 plate.

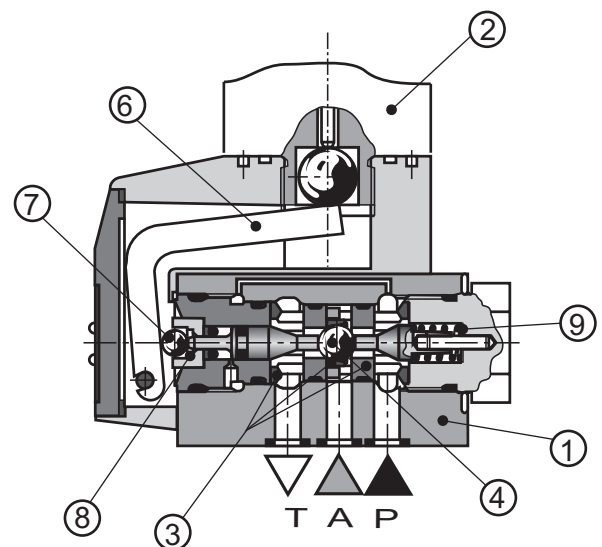

GENERALITY

Direct current solenoid (1) its mechanical impact strength is approved by the CENELEC for explosion proof equipment.

Insulation to IP 66, it can work in tropical climates.

Direct current solenoid has the advantages of :

- slow movement of the control spool.
- energized maintenance of the control valve in intermediary position, is not detrimental to the solenoid.

The solenoid housing can be oriented in steps of 90° on hydraulic valve.

ELECTRIC CONNECTION

Junction in box for group I and IIB+H2

The terminal box (3) can be oriented in steps of 180° on the solenoid housing (1).

The electrical connector on the outlet terminal box (6) can be arranged horizontally (on terminal box 3) suitable for cable gland.

One earth connection (5) is available inside or outside the terminal box .

Model H1, H2, ... (Box) Horizontal connection.

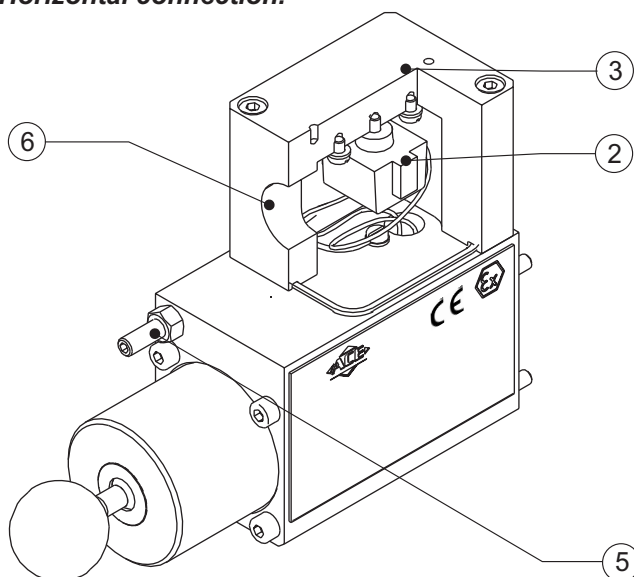

2 different protection modes.

1) Protection EEx "d"
On terminal strip (2A) inside the explosion proof terminal (3A) box suitable for 0.5 to 1.5 mm² with cable gland EEx "d".

2) Protection EEx "e"
On terminal strip (2B) inside the increased safety terminal box (3B) suitable for 0.5 to 2.5 mm² with cable gland EEx "e".

The terminal box is produced in aluminium as standard, but production in STEEL possible on request.

ELECTRIC CONNECTION

Junction On Female Taped Flange For Group II Only.

Connection with threaded rigid conduit approved in group II only.
Seal integrated in the housing.

It is produced according to the "d" protection mode using a certified type of rigid conduit (threaded tube).

Seal integrated in the housing.

Available with either a horizontal (BH) or vertical (BI) electrical output .

Earth connexion (5).

The lead wire length normally supplied is 1.5 meter.
Active lead wires (7).
Earth lead wire (8).

Other lengths to order.

Model "BI" (Flange)

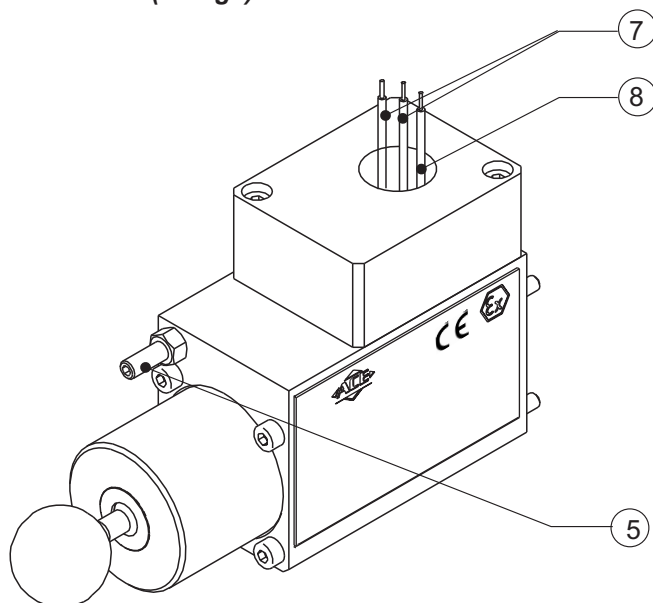

Model "BH" (Flange)

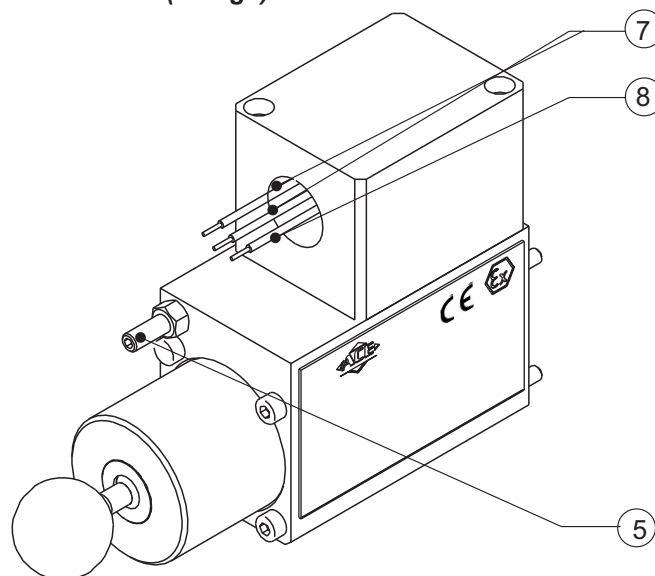

Cable Gland Recognized

PE option (see page 5)

Cable gland for unarmored cable EEx"d" IIC recognized in 1/2" NPT and with a diameter of Ø6 to Ø9 mm over a sealing shield.

Also available in EEx"d", EEx"e" group I or group IIC for armoured, unarmored or mineral cable : Consult us.

REFERENCES

- SEW6 3X-7/ 420

Mineral Oil **M**

2/2 switching position symbol P & N
3/2 switching position symbol C & U
4/2 switching position symbol D & Y **2
3
4**











**P
N
U
C
D
Y**

Serie number **3X-7**

Hydraulic Housing serie **420**



<p><i>For use when the flow is greater than the valve capacity, fitted in P line.</i></p>	Throttle Ø 1.2 MM :	B12
	Throttle Ø 1.5 MM :	B15
	Throttle Ø 1.8 MM :	B18
	Throttle Ø 2.0 MM :	B20
	Throttle Ø 2.2 MM :	B22

Without check valve
With check valve **P**

- EX700 - -							
	<table border="1" style="width: 100%;"> <tr> <td style="width: 30%;">No Code</td> <td>Standard temp +40° C</td> </tr> <tr> <td>TX-60</td> <td>Temp. Declass +60° C</td> </tr> <tr> <td>TX-50</td> <td>Temp. declas +50° C See table page 6</td> </tr> </table>	No Code	Standard temp +40° C	TX-60	Temp. Declass +60° C	TX-50	Temp. declas +50° C See table page 6
No Code	Standard temp +40° C						
TX-60	Temp. Declass +60° C						
TX-50	Temp. declas +50° C See table page 6						
	<table border="1" style="width: 100%;"> <tr> <td style="width: 30%;">*</td> <td>Aluminium Box (Standard)</td> </tr> <tr> <td>ST</td> <td>Steel Box</td> </tr> </table>	*	Aluminium Box (Standard)	ST	Steel Box		
*	Aluminium Box (Standard)						
ST	Steel Box						
	<table border="1" style="width: 100%;"> <tr> <td style="width: 30%;">d e</td> <td>With Ex d box . With Ex e box. No code. : For Ex d taped flange</td> </tr> </table>	d e	With Ex d box . With Ex e box. No code. : For Ex d taped flange				
d e	With Ex d box . With Ex e box. No code. : For Ex d taped flange						
	<table border="1" style="width: 100%;"> <tr> <td style="width: 30%;">1 2 3 4 5 6 7</td> <td>: 1/2" NPT : PG 11 (Only EEX e) : PG 13.5 (Only EEX e) : PG 16 (Only EEX e) : M 16 x 1.50 : M 20 x 1.50 : M 22 x 1.50</td> </tr> </table>	1 2 3 4 5 6 7	: 1/2" NPT : PG 11 (Only EEX e) : PG 13.5 (Only EEX e) : PG 16 (Only EEX e) : M 16 x 1.50 : M 20 x 1.50 : M 22 x 1.50				
1 2 3 4 5 6 7	: 1/2" NPT : PG 11 (Only EEX e) : PG 13.5 (Only EEX e) : PG 16 (Only EEX e) : M 16 x 1.50 : M 20 x 1.50 : M 22 x 1.50						
	<table border="1" style="width: 100%;"> <tr> <td style="width: 30%;">H BI BH</td> <td>Horizontal connection on the box. For taped flange, wire lg1.5m Gr II only (Vertical). For taped flange, wire lg1.5m Gr II only (Horizontal).</td> </tr> </table>	H BI BH	Horizontal connection on the box. For taped flange, wire lg1.5m Gr II only (Vertical). For taped flange, wire lg1.5m Gr II only (Horizontal).				
H BI BH	Horizontal connection on the box. For taped flange, wire lg1.5m Gr II only (Vertical). For taped flange, wire lg1.5m Gr II only (Horizontal).						
	<table border="1" style="width: 100%;"> <tr> <td style="width: 30%;">P V</td> <td>Control pushbutton Screw Control No code : Without control pushbutton</td> </tr> </table>	P V	Control pushbutton Screw Control No code : Without control pushbutton				
P V	Control pushbutton Screw Control No code : Without control pushbutton						
	<table border="1" style="width: 100%;"> <tr> <td style="width: 30%;">T...</td> <td>Temperature range see table on page 6 (For group II only).</td> </tr> </table>	T...	Temperature range see table on page 6 (For group II only).				
T...	Temperature range see table on page 6 (For group II only).						
	<table border="1" style="width: 100%;"> <tr> <td style="width: 30%;">DC AC</td> <td>Solenoid energized in direct current. Solenoid energized in alternating current. (Only for version H d)</td> </tr> </table>	DC AC	Solenoid energized in direct current. Solenoid energized in alternating current. (Only for version H d)				
DC AC	Solenoid energized in direct current. Solenoid energized in alternating current. (Only for version H d)						
	<table border="1" style="width: 100%;"> <tr> <td style="width: 30%;">12 220</td> <td>Solenoid power supply in Volt. 12, 22, 24, 48, 96, 110, 200, 220 ... See table on page 6 for correspondance with the temperature range T4, T5, T6.</td> </tr> </table>	12 220	Solenoid power supply in Volt. 12, 22, 24, 48, 96, 110, 200, 220 ... See table on page 6 for correspondance with the temperature range T4, T5, T6.				
12 220	Solenoid power supply in Volt. 12, 22, 24, 48, 96, 110, 200, 220 ... See table on page 6 for correspondance with the temperature range T4, T5, T6.						
	<table border="1" style="width: 100%;"> <tr> <td style="width: 30%;">EX700</td> <td>Explosion proof European standards ATEX Directive. </td> </tr> <tr> <td>IEC700</td> <td>International certification(IECEx). Only for Ex d version </td> </tr> <tr> <td>KEX700</td> <td>Korean certification. Only for Ex d version </td> </tr> </table>	EX700	Explosion proof European standards ATEX Directive. 	IEC700	International certification(IECEx). Only for Ex d version 	KEX700	Korean certification. Only for Ex d version 
EX700	Explosion proof European standards ATEX Directive. 						
IEC700	International certification(IECEx). Only for Ex d version 						
KEX700	Korean certification. Only for Ex d version 						
	<table border="1" style="width: 100%;"> <tr> <td style="width: 30%;">M</td> <td>Solenoid for use in mining (group I). No code : Solenoid for use in explosive atmosphere (Group II). (groupe II).</td> </tr> </table>	M	Solenoid for use in mining (group I). No code : Solenoid for use in explosive atmosphere (Group II). (groupe II).				
M	Solenoid for use in mining (group I). No code : Solenoid for use in explosive atmosphere (Group II). (groupe II).						

CARACTERISTICS

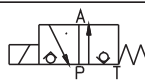
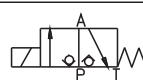

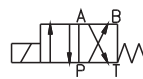
HYDRAULIC

Maximum operating pressure : Ports A, B, P.	Bar	Up to ... 250
Maximum operating pressure : Port T.	Bar	Up to ... 100
Maximum flow	L/Mn	(see operating curves of pressure drop page 8)
Hydraulic fluid	.	Mineral oils
Viscosity range	mm ² /s	1380
Fluid temperature range	(°C)	-30°+70
Weight :	- valve without plate (Kg) - valve with plate (Kg)	4.0 4.4
Mounting position :	- 3 Positions - 2 Positions	Optional Optional
Standard symbol :	- 2 positions	 U  C
	- 3 positions	 D  Y

ELECTRIC

Continous voltages available	V/DC	12	22	24	24	48	96	110	200	220	
Alternative voltages available*	V/AC	----	24	----	----	----	110	----	220	----	
Temperature range with ambiente 40° C		T6	T6	T5	T6	T6	T6	T6	T6	T6	
Temperature range with ambiente 50° C		T5	T5	T4	T5	T5	T5	T5	T5	T5	
Temperature range with ambiente 60° C		T5	T5	T4	T5	T5	T4	T5	T5	T5	
Power requirement	VA	13.6	13.6	16.4	13.7	13.2	13.6	13.8	13.6	13.6	
Protection index		IP66									
Duty cycle		100%									
Maximum coil temperature		130°C									
Outlet connection on terminal box or taped flange		1/2"NPT-PG11-PG13.5-PG16-M16x1.5-M20x1.5-M22x1.5									

HOMOLOGATIONS

European classification code	 IIBGD ou  IM2 EEx d I ou EEx d IIB+H2 ou EEx de I ou EEx de IIB+H2 ou	Homologation Number INERIS 02ATEX0024X Product Quality Notification INERIS 03 ATEXQ718
International classification code	Ex d IIB + H2 T6, T5 or T4 Gb	Homologation Number IECEX INE 11.0011X
Korean classification code	Ex d IIB + H2 T6, T5 or T4 Gb	Homologation Number 15-AV4BO-0143X

DIMENSIONS

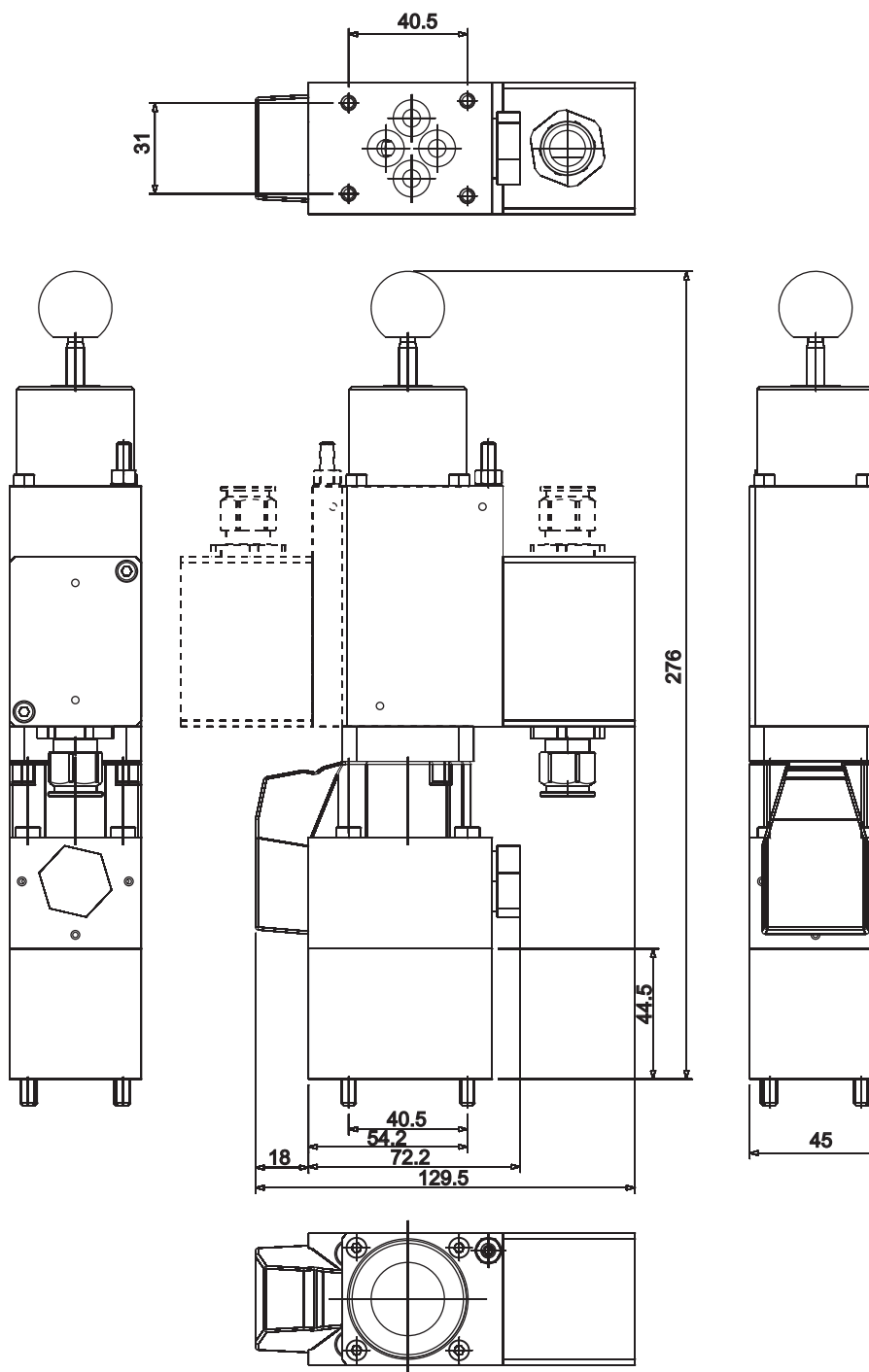

HYDRAULIC VALVE CONNECTION

HYDRAULIC VALVE
CONNECTION
SIZE 6 TYPE CETOP 3

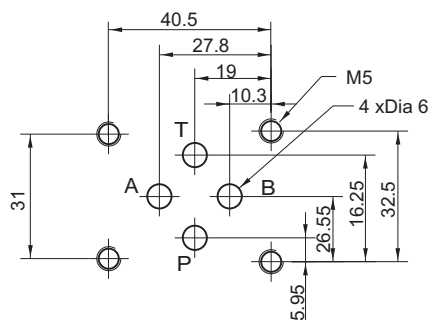

CURVES OF PRESSURE DROP

VALVES 3 And 4 PORTS - 2 POSITIONS

- 1 : M-3SEW6 U or C , A to T
- 2 : M-3SEW6 U , P to A
- 3 : M-3SEW6 C , P to A

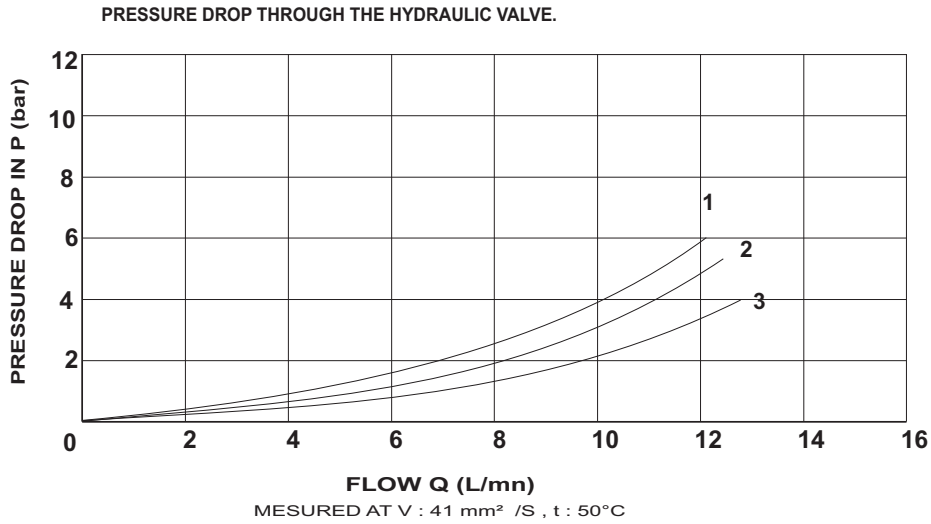

CARTDRIGE CHECK VALVE

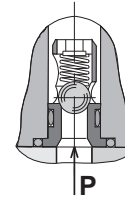
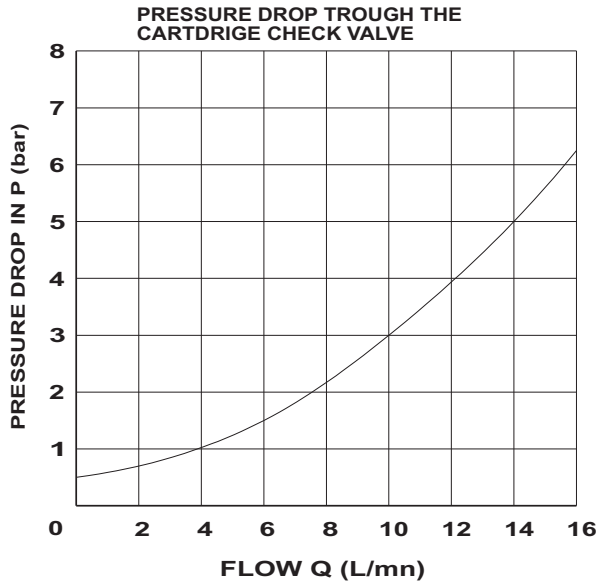

CARTDRIGE CHECK VALVE

For the valves 3/2 the cartridge is inserted in port P of the check valve.

For the valves 4/2 the cartridge is inserted in port P of the plate N+1.

CARTRIDGE THROTTLE

CARTRIDGE THROTTLE :

For use when the flow is greater than the valve capacity, fitted in P line.

For the valves 3/2 the cartridge is inserted in port P of the check valve.

For the valves 4/2 the cartridge is inserted in port P of the plate N+1.

